

General Setup Instructions

- The setup instructions are created specifically for your configuration.
- Setup instructions are laid out sequentially in levels, including exploded views and a logical series of steps for assembly. We encourage you to study the instructions before attempting to assemble your exhibit.

Cleaning and Packing

- Use non-abrasive cleaners when cleaning extrusions or ECO Glass inserts.
- Use mild cleaners and soft materials such as cotton to clean all laminates.
- Keep exhibit components away from extreme heat and long exposure to sun light. This will prevent warping and fading.
- Retain all packing material for ease of re-packing. This protects the exhibit components and keeps each part organized.

Disassembling

- When disassembling exhibit, tighten all setscrews to prevent loss of hardware in the shipping process.

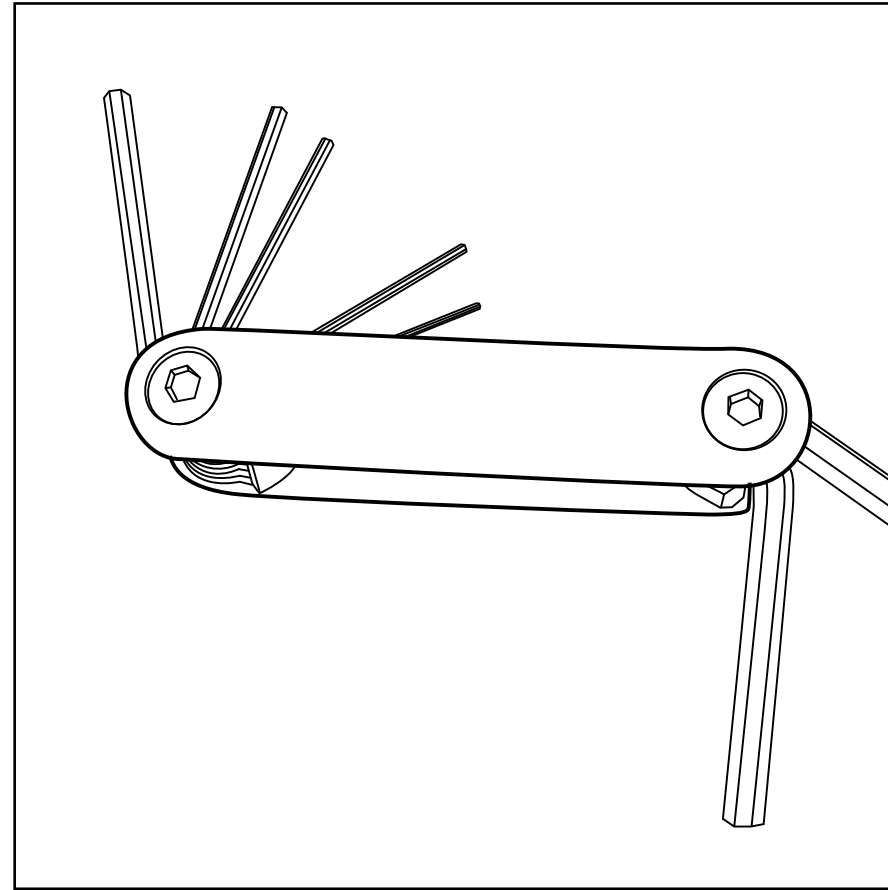

Hex Tool for Assembling Exhibit

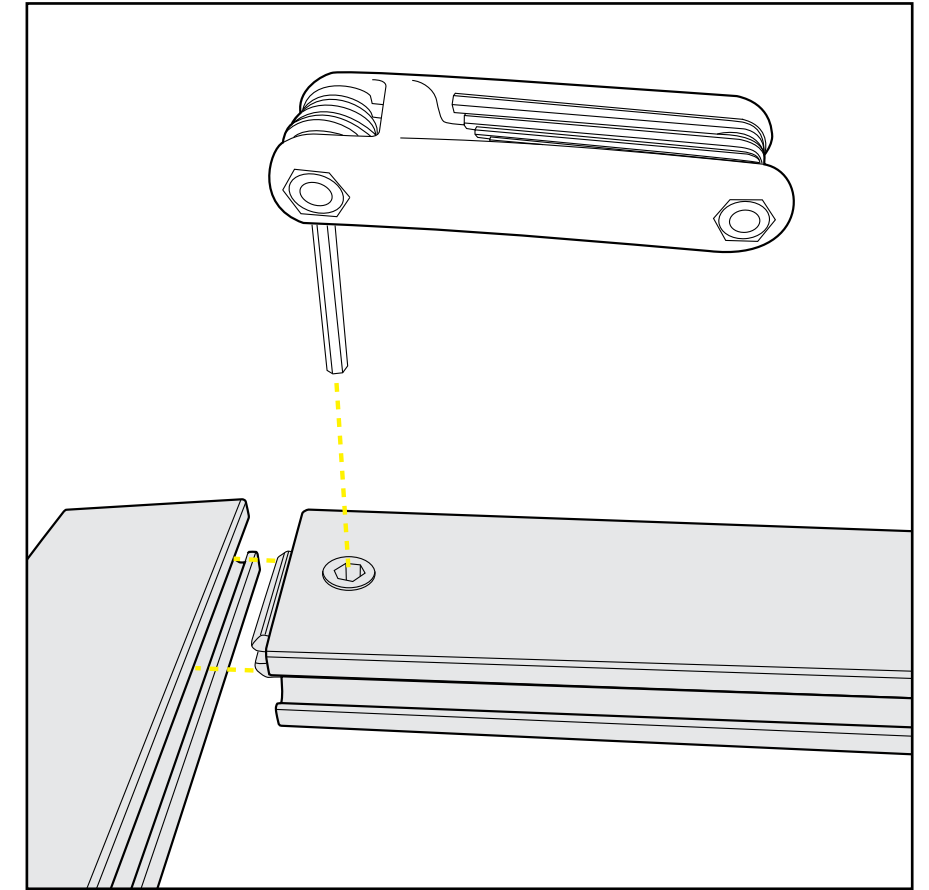

Extrusion Lock Connectors

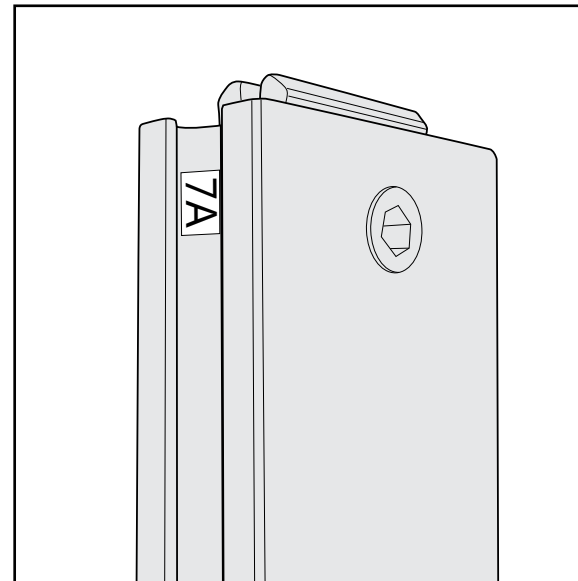

Numbering Instructions for Setups/Packing

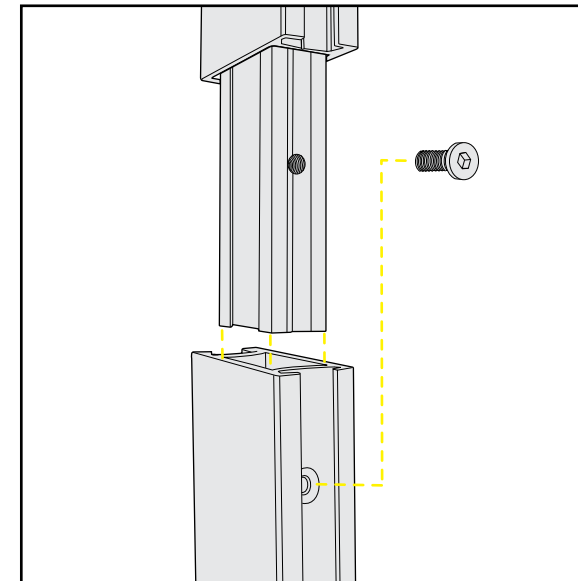

Inline Connection between Extrusions

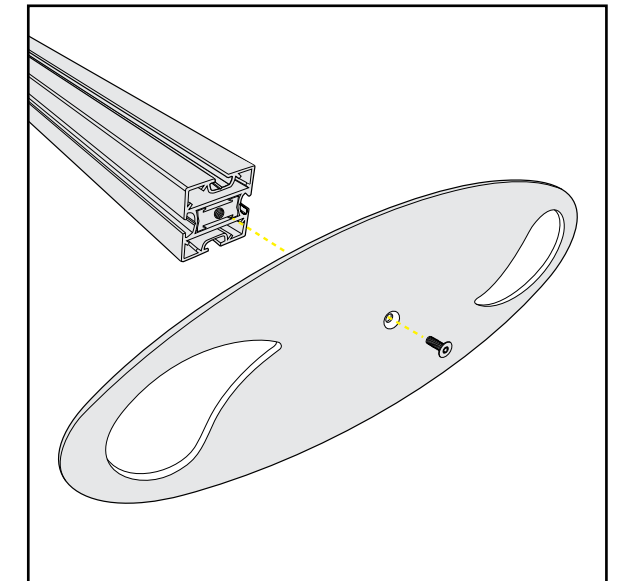

Baseplate Connection for Vertical Extrusions

Item	Qty.	Description
1	1	40"h Q918 Vertical Extrusion
2	1	40"h Q918 Vertical Extrusion
3	1	48"h S44 Vertical Extrusion
4	1	40"h Q918 Vertical Extrusion
5/5A	1/1	19.25" Z45 curved Horizontal Extrusion
6/6A	1/1	8" Z45 curved Horizontal Extrusion
7/7A	1/1	19.25" Z45 curved Horizontal Extrusion

Steps

- 1) Attach lower Horizontals [5,6,7] between Verticals [1,2,3,4] as shown.
- 2) Insert Infills and secure with upper Horizontals [5A,6A,7A].
- 3) Place shelf on top of shelf pins.
- 4) Place counter top on top of assembled base.

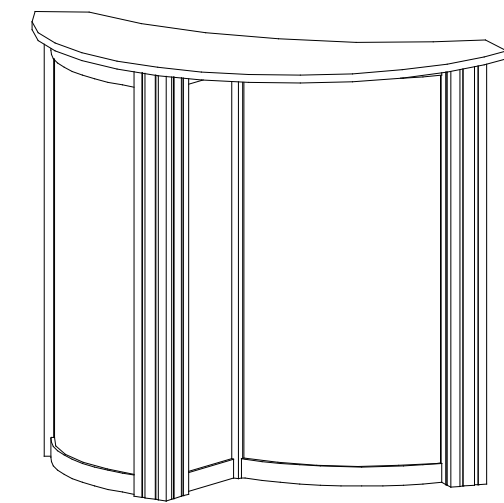
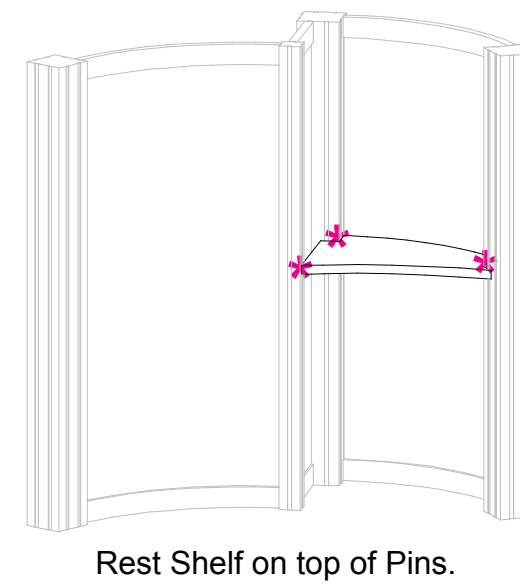
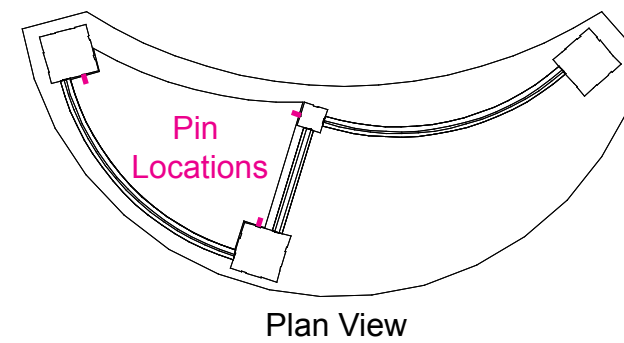
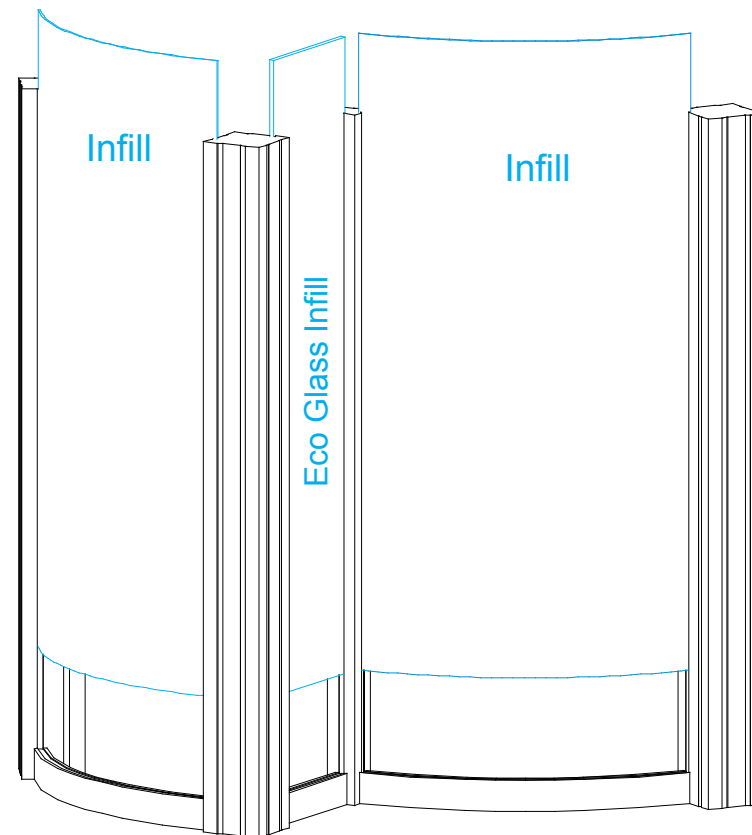
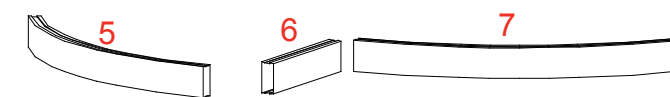
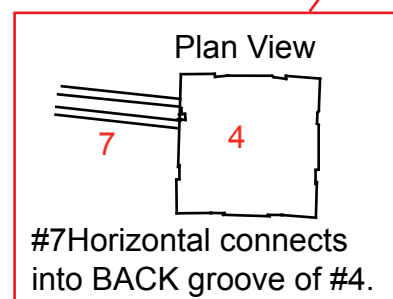
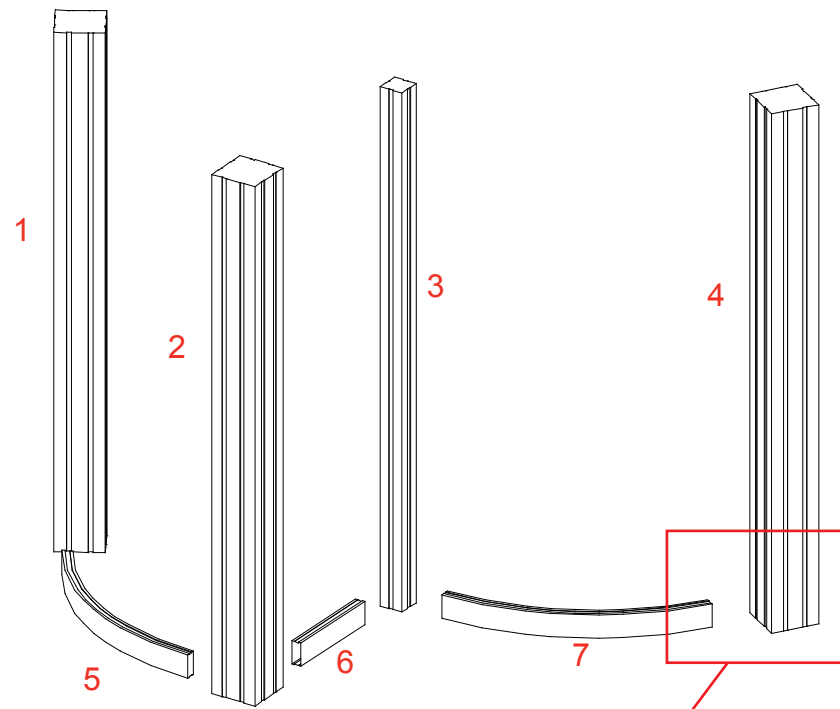

When assembled

Place Counter on top of Assembled Base

